



**18 GHz SMA LATCHING S.P.6 T. SWITCH**

OPTIONS : INDICATOR /SELF CUT-OFF /AUTO RESET /SUPP.DIODES

**R F CHARACTERISTICS**

NUMBER OF WAYS : 6  
 FREQUENCY RANGE : 0 - 18 GHz  
 IMPEDANCE : 50 Ohms

|                 |         |         |         |          |
|-----------------|---------|---------|---------|----------|
| FREQUENCY (GHz) | 0 - 3   | 3 - 8   | 8 -12.4 | 12.4- 18 |
| V.S.W.R <=      | 1.20    | 1.30    | 1.40    | 1.50     |
| INSERT. LOSS <= | 0.20 dB | 0.30 dB | 0.40 dB | 0.50 dB  |
| ISOLATION >=    | 80 dB   | 70 dB   | 60 dB   | 60 dB    |
| AVER. POWER (*) | 120 W   | 80 W    | 60 W    | 50 W     |

**ELECTRICAL CHARACTERISTICS**

ACTUATOR : LATCHING  
 NOMINAL CURRENT AT 25° C (±10%) : 375 mA  
 ACTUATOR VOLTAGE (Vcc) : 28V (24 to 30V) / NEGATIVE COMMON  
 TERMINALS : solder pins (250°C max./30 sec.)  
 INDICATOR RATING : 1 W / 30 V / 100 mA  
 SELF CUT-OFF TIME : 40 ms < CT < 120 ms

**MECHANICAL CHARACTERISTICS**

CONNECTORS : SMA female per MIL C 39012  
 LIFE : 5.000.000 cycles per position  
 SWITCHING TIME (nominal voltage;25° C) : < 40 ms  
 CONSTRUCTION : splashproof  
 WEIGHT : < 220 g

**ENVIRONMENTAL CHARACTERISTICS**

OPERATING TEMPERATURE RANGE (°C) : -40 , +85  
 STORAGE TEMPERATURE RANGE (°C) : -55 , +85

(\* : average power at 25° C per RF path)

This information is given as an indication. In the continual goal to improve our products, we reserve the right to make any modifications judged necessary

This information is given as an indication. In the continual goal to improve our products, we reserve the right to make any modifications judged necessary

**DRAWING**

General tolerance: ± 0,5 mm

**R573 493600**

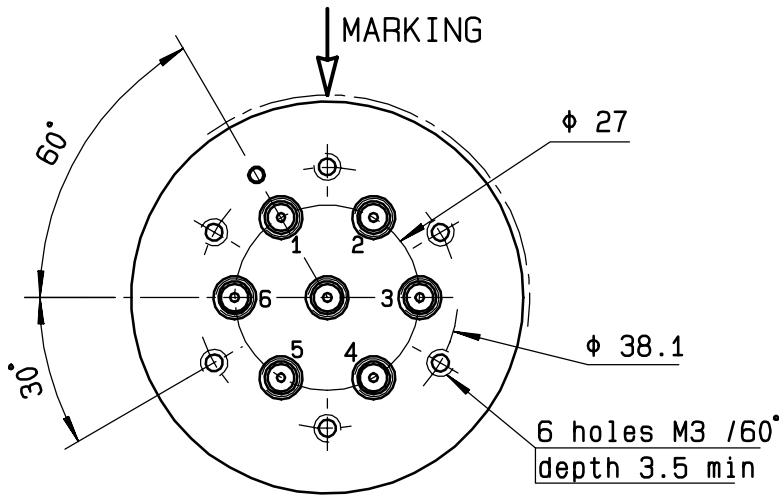

| Voltage | RF continuity | Ind. |
|---------|---------------|------|
| -C +1   | IN ↔ 1        | D.E  |
| -C +2   | IN ↔ 2        | D.F  |
| -C +3   | IN ↔ 3        | D.G  |
| -C +4   | IN ↔ 4        | D.H  |
| -C +5   | IN ↔ 5        | D.I  |
| -C +6   | IN ↔ 6        | D.J  |

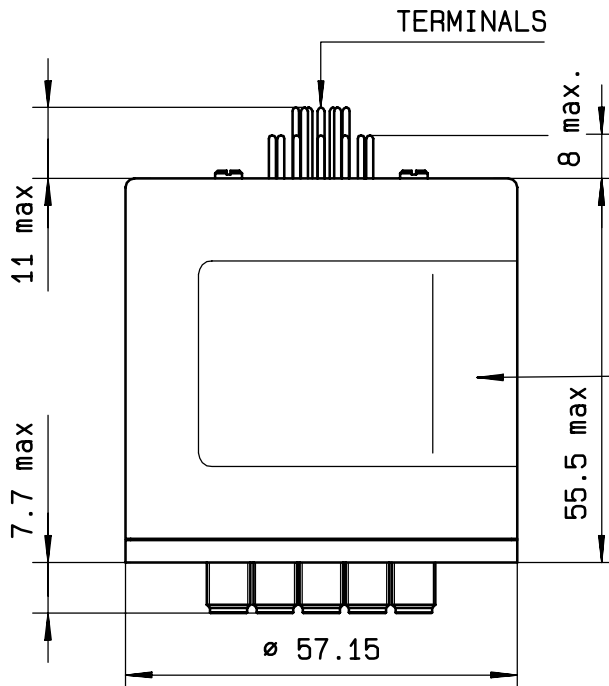

MARKING TOP VIEW (TERMINALS)

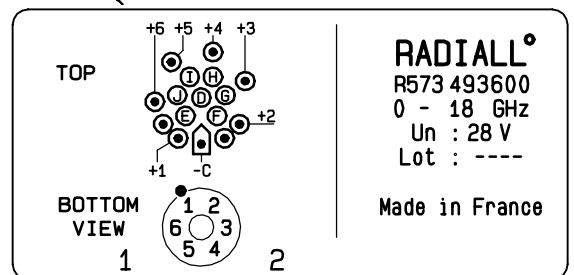

**SCHEMATIC DIAGRAM**

